



Just the Facts:

# Why New York City Chose Centrisys

## Rigorous analysis showed a clear winner for one of the largest dewatering upgrade projects in the country

The Wards Island Wastewater Treatment Plant is the second largest of the 14 wastewater treatment facilities in New York City, serving about 1 million people with an average dry-weather flow capacity of 275 MGD.

As part of a series of upgrades to improve pollution control and treatment efficiency, the NYC Department of Environmental Protection set out to evaluate dewatering centrifuge technology to replace the existing centrifuges at Wards Island. After rigorous bidding, NYC choose to install (16) CS26-4 Centrisys decanter centrifuge.

## On balance of objective criteria, Centrisys' system deemed superior

Using a matrix incorporating an array of weighted criteria established to seek the greatest overall value, CDM Smith ranked the products and manufacturers by their total scores.

Despite being the second highest in capital cost, the Centrisys CS26-4 came out on top due to facts including:

- Highest G-volume of installed centrifuges
- Highest torque capacity
- Lowest measured power consumption\*
- Second-lowest operating costs
- Most installations worldwide for machines of this size and capacity
- The only centrifuge using an advanced hydraulic scroll drive instead of a gearbox
- Minimal structural and mechanical modifications needed for installation

\*See chart on back. Bid #5 power consumption was a calculation.

## Five Competing Centrifuge Systems of Similar Capacity Considered

The DEP enlisted one of the world's foremost water quality consulting firms for a feasibility study comparing the following models:

- Alfa Laval G2-115
- Andritz CP4-1.2 (a retrofit using the same frame)
- Andritz D6LX
- Westfalia CF700
- Centrisys CS26-4

All these models were mid-feed or counter-current designs using AC variable-frequency drives (VFDs) for the main drive motors. All evaluated centrifuges, with the exception of Centrisys, used various gear drive configurations – ranging from two- to four-stage planetary or cyclo-gear reducers. The Centrisys CS26-4 operates using its standard back drive system – the Viscotherm hydraulic scroll drive based on Rotodiff® technology, controlled through a VFD.



## Better than Specification Performance

Performance testing for the Wards Island CS26-4 centrifuge installation demonstrated **better than specification performance results**.

- 50% power reduction compared to old centrifuges
- 25% higher throughput compared to old centrifuges
- 17% lower polymer consumption than specification
- 1% drier cake than specified and guaranteed
- 99% capture at 270 gpm (4% higher than specified and guaranteed)



### The Centrisys Advantage: Easy Integration

The Centrisys engineering team integrated a centrifuge stand, diverter gate and interconnecting pipework into the plant design. These design elements created a “drop in place” centrifuge system, allowing for easy integration with only few minor modifications to the existing floor plan.

### What's Next?

- **Hunts Point:** (16) CS26-4 scheduled for shipping January 2018, completing January 2019
- **26th Ward:** (16) CS26-4 scheduled for shipping June 2018, completing January 2020

### Wards Island Performance Test - July 12-13, 2017

The data acquired below is from the Wards Island Process Control Laboratory. The New York DEP randomly selected Centrisys CS26-4 decanter centrifuges #5703 and #5705, from the 10 installed centrifuges at the time, to conduct the 48-hour performance test. The gpm was kept around 250, but each unit demonstrated better than specification performance while running at 270 gpm for two hours. This was to meet the solids load of 2,210 lb/hr as the feed solids was below 1.6%, the average feed solids, during the two hours.

	Flow Rate [GPM]	Cake Solids [% TS]	Polymer Dose [lb/dry ton]	Capture Rate [% w/w]
<b>Bid Specs</b>	<b>250</b>	<b>26%</b>	<b>36</b>	<b>95%</b>
Unit 5703	252.5	26.7%	29.8	99%
Unit 5705	252.5	27.1%	28.2	99%

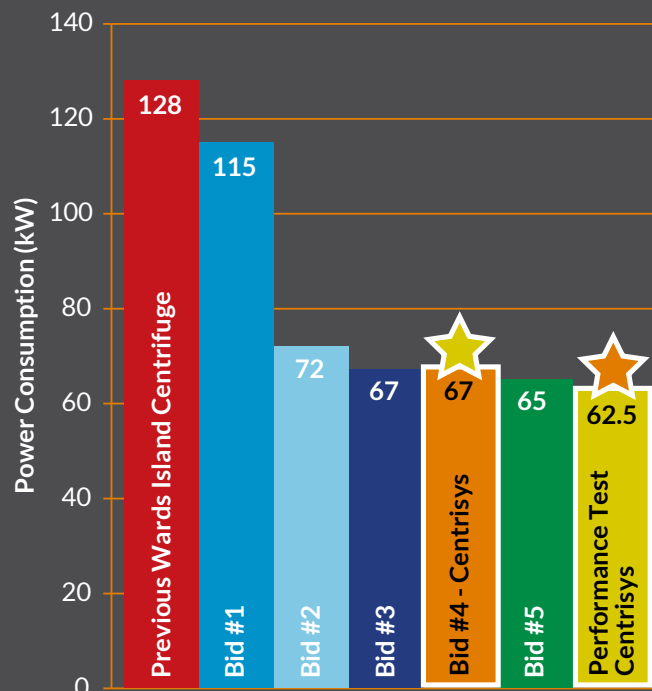

## Dewatering Specs Centrisys CS26-4 Centrifuge Wards Island

- Flow Rate – 200-400 GPM
- G-Force – 3,000
- Torque – 30,000 Nm
- Standard Main Motor HP – 100 HP
- Scroll HP – 25 HP
- Beach Angle – 15 degrees
- Bowl Diameter – 26 inches
- Bowl Cylinder Length – 90 inches

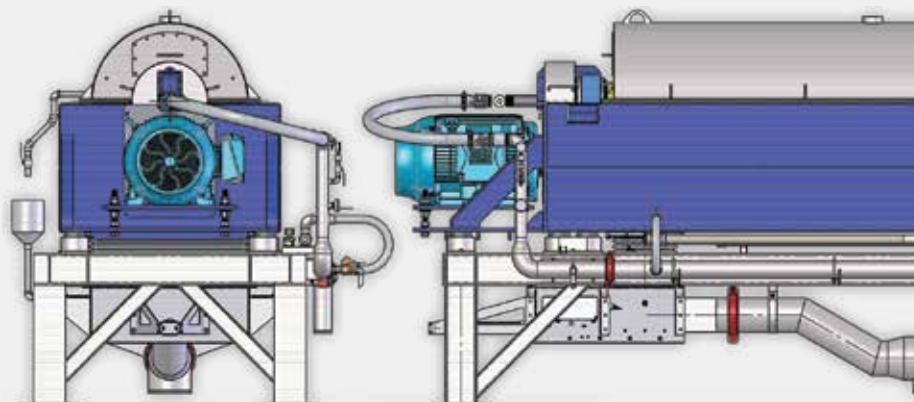

## Questions about Centrisys technologies?

**Corporate** 9586 58th Place | Kenosha, WI 53144 USA P +1 (262) 654-6006 E info@centrisys.com  
**Global Presence** North America | South America | Europe | Middle East | China



ISO 9001:2015