



DEWATERING CENTRIFUGES



SKID SYSTEMS



TRAILER SYSTEMS

The Right Solution The Fastest Payback

In 1987, Centrisys designed and built its first centrifuge around what was learned in the field by servicing competitor's equipment in both municipal and industrial applications. Thirty years later, the Centrisys engineering team continues to benefit from problem-solving, learning what does and does not work in the real world and takes that knowledge to continue Centrisys' lifelong commitment to brand excellence. By providing the most efficient, robust decanter centrifuges, Centrisys gives our customers the results they need.

- Increased solids handling
- Reduced polymer consumption
- Higher flow rates
- Lower operating and maintenance costs
- Reduced hauling fees
- Lowest energy consumption
- Continuous operation
- Lowest installed horsepower
- Driest cake

Centrisys centrifuges can be customized for unique application requirements. For further information about customized centrifuges, contact your Centrisys sales representative.



Why Choose Centrisys?

- 1 U.S.A. Engineered and Manufactured:** A Centrisys centrifuge is designed, engineered and built with pride at our corporate headquarters in Kenosha, Wisconsin
- 2 Centrisys-Viscotherm Scroll Drive:** The most efficient in the industry with a simplified design; highest torque to weight ratio with the best process control
- 3 Highest Quality:** All structural bowl components are centrifugally cast or forged for ultimate integrity and strength
- 4 Advanced Wear Protection:** Progressive wear protection prolongs the life of your centrifuge, increases uptime, optimizes performance and reduces service and maintenance costs
- 5 Scroll Design and Development:** Axial flow design promotes settling of even the finest solids, improves the recovery rate and reduces polymer consumption
- 6 Centrifuge Energy Recovery System (CERS):** The centrifuge can restart anytime during a shutdown period (on the fly or standstill) and prevents a costly dis-mantle to free-up a blocked centrifuge



Dewatering Solutions: USA Built, Sold & Serviced Around the World

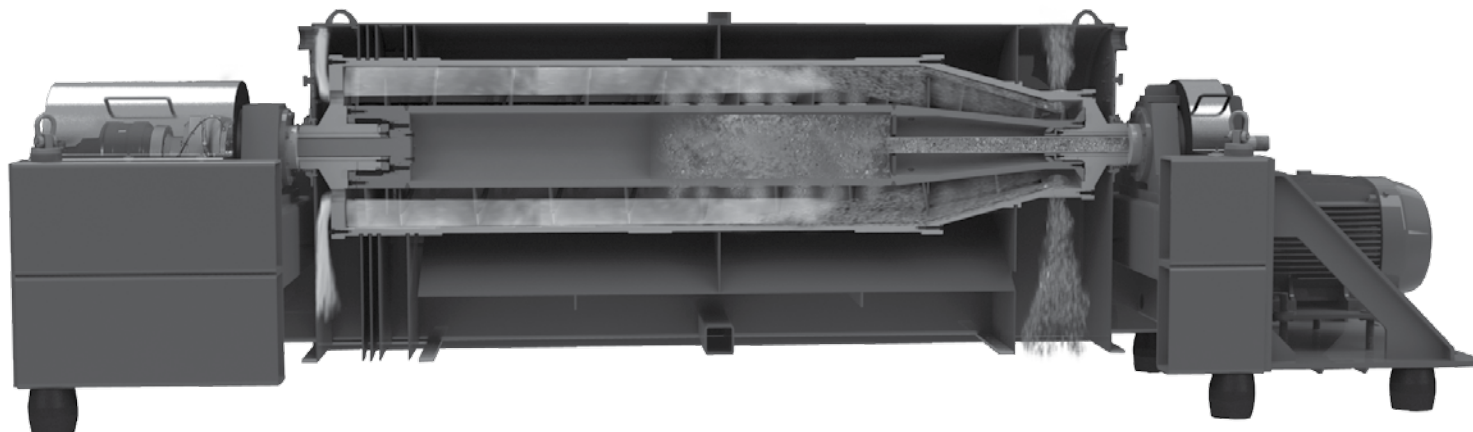

Dewatering Decanter Centrifuges CS Series									
	CS10-4	CS14-4	CS18-4	CS18-4HC	CS21-4	CS21-4HC	CS26-4EV	CS26-4	CS30-4
Phase	2/3	2/3	2/3	2/3	2/3	2/3	2/3	2/3	2/3
Feed Capacity* gpm (m ³ h)	5-35 (1-8)	20-60 (5-14)	50-100 (11-23)	75-125 (17-29)	100-175 (23-40)	150-225 (34-51)	150-320 (34-73)	200-400 (45-90)	300-700 (68-159)
Weight lbs (kgs)	2,000 (910)	3,800 (1,725)	6,500 (2,950)	8,200 (3,720)	8,500 (3,860)	10,000 (4,550)	16,500 (7,490)	18,500 (8,400)	30,000 (13,600)
Total Installed Power HP (kw)	20 (15)	40 (30)	50 (38)	60 (45)	75 (56)	90 (68)	140 (105)	165 (123)	275 (205)
Avail. Shallow Pool/Angle	Yes	Yes	Yes	Yes	Yes	Yes	Yes	Yes	Yes
Auto Lube System	Yes	Yes	Yes	Yes	Yes	Yes	Yes	Yes	Yes
L x W x H in (m)	89 x 44 x 27 (2.3 x 1.1 x 0.7)	122 x 34 x 31 (3.1 x 0.9 x 0.8)	151 x 44 x 41 (3.8 x 1.1 x 1.0)	175 x 44 x 47 (4.5 x 1.1 x 1.2)	175 x 44 x 47 (4.5 x 1.1 x 1.2)	190 x 45 x 53 (4.8 x 1.4 x 1.4)	210 x 56 x 62 (5.3 x 1.4 x 1.6)	225 x 56 x 62 (5.7 x 1.4 x 1.6)	258 x 74 x 75 (6.6 x 1.9 x 1.9)
Cake Dryness	Up to 40% depending on process type and condition								

*Feed capacity based on municipal applications. Actual throughput based on sludge characteristics. Centrisys reserves the right to change specs without prior notification.

Questions about Centrisys technologies? Contact us today!

Corporate 9586 58th Place | Kenosha, WI 53144 USA P +1 (262) 654-6006 E info@centrisys.com

Global Presence North America | South America | Europe | Middle East | China



ISO 9001:2015

POCS2017v8EN